

marine propulsion family by norpro[®]

Model **4300TRSF102hp**
4300TR1SF123hp
4300TRCSF140hp

Engine:
ISUZU 4BG1T TURBOCHARGED

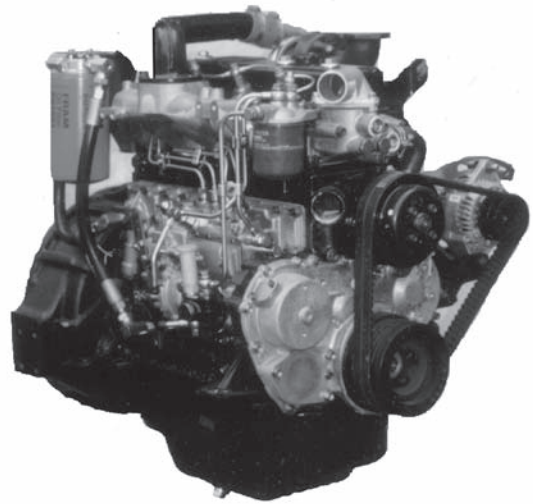

(some options may be shown)

Main Specifications

Type.....4 Cylinder, 4 cycle, water cooled, OHV
Fuel system.....direct injection
Bore & Stroke.....4.13 x 4.92 in.
Piston Displacement.....262 cu. in.
Dry Weight835 lbs.
Dimensions - LxWxH(4300T)35.5x26x33.6in.
Coolant Capacity (Block)9.0 qts.
Lube Oil Capacity13.74 qts.
Engine RotationCounter clockwise from flywheel
Compression Ratio17:1

5 year/5000 hour warranty on engine

Standard Features

Alternator12V - 60A
Voltage RegulatorIntegral 12V
Starter.....12V - 2.5 kW
ExhaustFaces Upwards
Flywheel HousingSAE #3
Flywheel10 in.
Cold Weather AidGlow plugs
Air FilterFoam
Cooling SystemKeel Cooled
Turbo4300T Only
Engine ShutdownElectric
CrankshaftTuftrided Hardened
PPG PaintElectric Blue

Marine Rating

4300TRSF

Intermittent gross @ sea level.....102 BHP @ 2500 RPM
Continuous gross @ sea level.....84 BHP @ 2500 RPM
Maximum Torque.....250 ft. lbs @ 1600 RPM

Options

Dual station instrument panels with Y harness
5', 10', 20', or 50' extention harnesses
Raw water pump
Oil drain hose kit
Auxiliary Crank Pulley
Center Line Mounts
Shallow Oil Pan
Bell housing mounts
Power steering pump
Pewter grey or Ultra white paint

Marine Rating

4300TR1SF

Intermittent gross @ sea level.....123BHP @ 2500 RPM
Continuous gross @ sea level.....115BHP @ 2500 RPM
Maximum.....306 ft. lbs @ 1600 RPM

Marine Rating

4300TRCSF

Intermittent gross @ sea level.....140BHP @ 2300 RPM
Continuous gross @ sea level.....132BHP @ 2300 RPM
Maximum.....358 ft. lbs @ 1600 RPM

Delivering excellence one product at a time

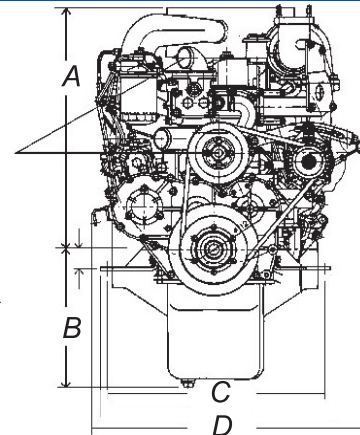
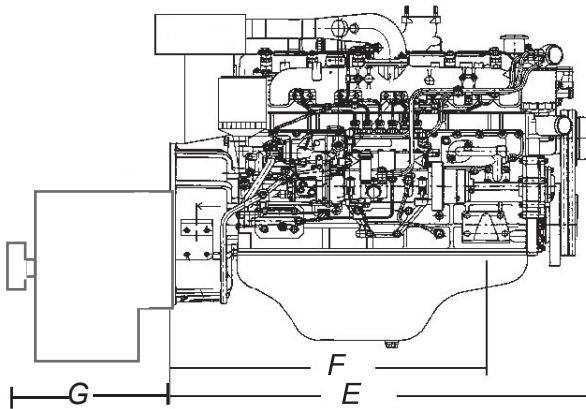

Model	A	B	C	D	E	F	ZF	G	Twin Disc	G
3100	20	9.5	N/A	21.8	31	22	45(A)	9	505A	8.82
3100T	22	9.5	N/A	21.8	31	22	45(A)	9	505A	8.82
4300TR	22.2	11.5	23	26	35.5	22.6	(63 or 220	14.5	5050(A)	12.78
4300TR1	22.2	11.5	23	26	35.5	22.6	A or H)	14.5	5050(A)	12.78
4300TRC	24.2	11.5	23	26	35.5	22.6	" "	14.5	5050(A)	12.78
6500TR	22.8	13.48	25	25.2	46.7	31.69	" "	14.5	5050(A)	12.78
6500TRC	22.8	13.48	25	25.2	46.7	31.69	" "	14.5	5050(A)	12.78
6500TRC-1	24.8	13.48	25	25.2	46.7	31.69	" "	14.5	5050(A)	12.78
7800T	N/A	N/A	24	39.2	54.2	N/A	28 A or H	14.5	5061(A)	13.18
9800TXC	26	17.75	24	27.2	47.25	31	26 A or H	14.5	5061(A)	13.18
1570TXC	N/A	N/A	N/A	40	68	N/A	311(A)	13.6	5082	15.48

Model	Rating	Cu. In.	Bobtail Weight	Cylinders	ZF	Weight	Twin Disc	Weight
3100	65BHP@2500	189	525	4	45(A)	62	505A	55
3100T	85BHP@2500	189	578	4	45(A)	62	505A	55
4300TR	102BHP@2500	264	835lbs.	4	(63 or 220	151/189	5050(A)	186
4300TR1	123BHP@2500	264	835lbs.	4	A or H)	151/189	5050(A)	186
4300TRC	140BHP@2300	264	915lbs.	4	" "	151/189	5050(A)	186
6500TR	182BHP@2200	396	1182lbs.	6	" "	151/189	5050(A)	186
6500TRC	202BHP@2200	396	1418lbs.	6	" "	151/198	5050(A)	186
6500TRC-1	222BHP@2500	396	1418lbs.	6	" "	151/198	5050(A)	186
7800T	253BHP@2000	475	1533lbs.	6	280(A/H)	161	5061(A)	215
9800TXC	353BHP@2000	600	1497lbs.	6	280(A/H)	161	5061(A)	215
1570TXC	483BHP@1800	958	2469lbs.	6	311(A)	308	5082	298

Authorized Sales & Service Dealer