

## marine propulsion family by **norpro**<sup>®</sup>

Model 6500TRSF 182hp

6500TRCSF 202hp

6500TRCSF-1 222hp

**Engine:**

**ISUZU DIESEL 6BG1 TURBOCHARGED**

EPA Certified\*

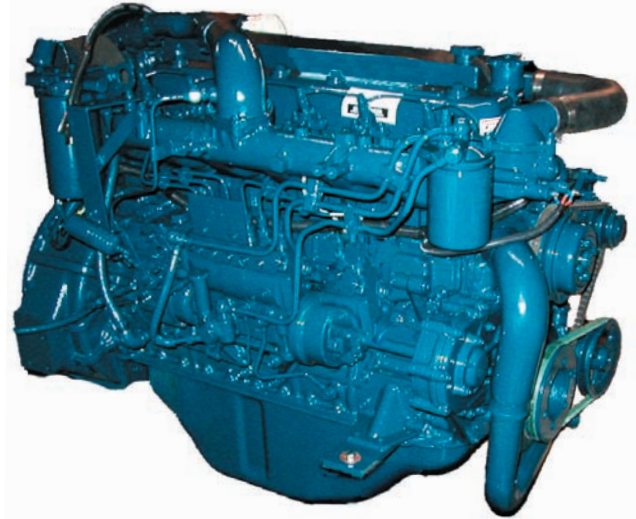

(some options may be shown)  
6500TRCSF

### Main Specifications

Type.....6 cylinder, 4 cycle, water cooled, OHV  
.....direct injection  
Bore & Stroke.....4.13 x 4.92 in.  
Piston Displacement.....396 cu. in.  
Dry Weight .....1182 lbs.  
Dimensions - L x W x H .....42.35 x 36.7 x 27.4 in.  
Coolant Capacity (Block).....12.7 qts.  
Lube Oil Capacity .....22.7 qts.  
Engine Rotation.....Counter clockwise from flywheel  
Compression Ratio .....17.5:1  
Decibel rating @2200 RPMs .....94.3  
5 year/5000 hour warranty

### Standard Features

Alternator.....12V - 60A  
Voltage Regulator.....Integral 12V  
Starter.....12V - 2.5 kW  
Exhaust Manifold.....Wrapped  
Flywheel Housing.....SAE #3  
Flywheel .....SAE 11.5 in.  
Cold Weather Aid.....Glowplugs  
Air Filter .....Foam  
Engine Shutdown .....Electric  
Crankshaft .....Tuftrided Hardened  
Pistons .....Sprayed Oil Cooled  
Paint .....Electric Blue

### Marine Rating

#### 6500TR

Intermittent gross @ sea level.....182 BHP @ 2200 RPM  
Continuous gross @ sea level.....162 BHP @ 2200 RPM  
Maximum Torque.....474 ft. lbs @ 1800 RPM

### Marine Rating

#### 6500TRC

Intermittent gross @ sea level.....202 BHP @ 2200 RPM  
Continuous gross @ sea level.....179 BHP @ 2200 RPM  
Maximum Torque.....525 ft. lbs @ 1800 RPM

### Options

Dual station instrument panels with Y harness  
5', 10', 20', or 50' extension harnesses  
Raw water pump  
Oil drain hose kit  
90 Amp Alternator  
PTO Stub Shaft  
Auxiliary Crank Pulley  
Center Line Mounts  
Bell housing mounts  
Power steering pump  
Cast iron wet exhaust manifold  
90 Amp alternator  
PTO stub shaft  
Pewter grey or Ultra white paint  
Drive Damper

### Marine Rating

#### 6500TRC-1\*

Intermittent gross @ sea level.....222 BHP @ 2500 RPM  
Continuous gross @ sea level.....179 BHP @ 2200 RPM  
Maximum Torque.....525 ft. lbs @ 1800 RPM

\*This model is not workboat EPA certified

## Delivering excellence one product at a time

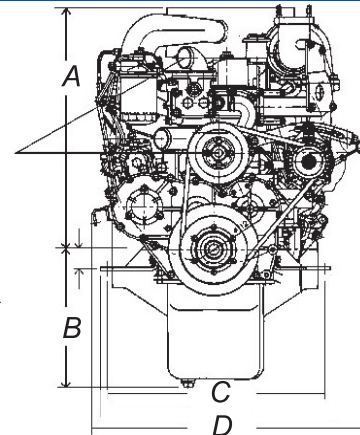
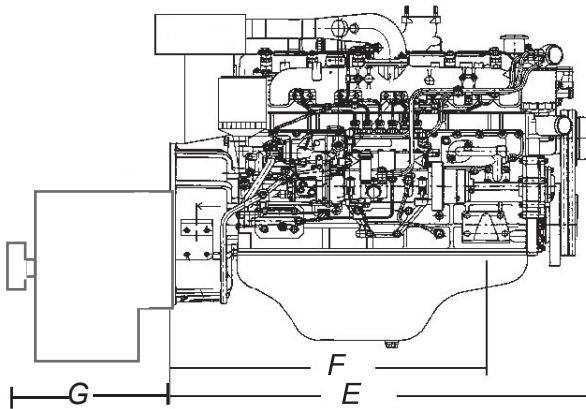

Model	A	B	C	D	E	F	ZF	G	Twin Disc	G
3100	20	9.5	N/A	21.8	31	22	45(A)	9	505A	8.82
3100T	22	9.5	N/A	21.8	31	22	45(A)	9	505A	8.82
4300TR	22.2	11.5	23	26	35.5	22.6	(63 or 220	14.5	5050(A)	12.78
4300TR1	22.2	11.5	23	26	35.5	22.6	A or H)	14.5	5050(A)	12.78
4300TRC	24.2	11.5	23	26	35.5	22.6	" "	14.5	5050(A)	12.78
6500TR	22.8	13.48	25	25.2	46.7	31.69	" "	14.5	5050(A)	12.78
6500TRC	22.8	13.48	25	25.2	46.7	31.69	" "	14.5	5050(A)	12.78
6500TRC-1	24.8	13.48	25	25.2	46.7	31.69	" "	14.5	5050(A)	12.78
7800T	N/A	N/A	24	39.2	54.2	N/A	28 A or H	14.5	5061(A)	13.18
9800TXC	26	17.75	24	27.2	47.25	31	26 A or H	14.5	5061(A)	13.18
1570TXC	N/A	N/A	N/A	40	68	N/A	311(A)	13.6	5082	15.48

Model	Rating	Cu. In.	Bobtail Weight	Cylinders	ZF	Weight	Twin Disc	Weight
3100	65BHP@2500	189	525	4	45(A)	62	505A	55
3100T	85BHP@2500	189	578	4	45(A)	62	505A	55
4300TR	102BHP@2500	264	835lbs.	4	(63 or 220	151/189	5050(A)	186
4300TR1	123BHP@2500	264	835lbs.	4	A or H)	151/189	5050(A)	186
4300TRC	140BHP@2300	264	915lbs.	4	" "	151/189	5050(A)	186
6500TR	182BHP@2200	396	1182lbs.	6	" "	151/189	5050(A)	186
6500TRC	202BHP@2200	396	1418lbs.	6	" "	151/198	5050(A)	186
6500TRC-1	222BHP@2500	396	1418lbs.	6	" "	151/198	5050(A)	186
7800T	253BHP@2000	475	1533lbs.	6	280(A/H)	161	5061(A)	215
9800TXC	353BHP@2000	600	1497lbs.	6	280(A/H)	161	5061(A)	215
1570TXC	483BHP@1800	958	2469lbs.	6	311(A)	308	5082	298

**Authorized Sales & Service Dealer**