

FUEL TYPE: PROPANE, NATURAL GAS

Model **125AF** 125kW

Engine: GM8.1

Type.....	8 cycles OHV V Type
No. of Cyl.....	8
Bore x Stroke (in.).....	4.25 x 4.37
Displacement (cu. in.).....	496.0
Compression ratio.....	9:1:1
Lube oil capacity (qts.).....	8
Cooling water capacity (qts.).....	28
Auto shutdown.....	Yes

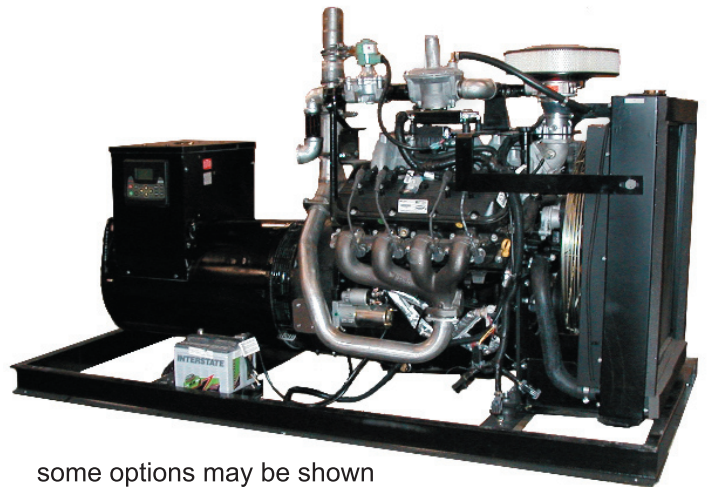

some options may be shown



optional enclosure

Alternative Fuel products are rated for industrial use, economical to operate and competitively priced. The above pictured Alternative Fuel Unit includes the following features: 8 cylinder engine, brushless generator, muffler, replaceable air filter, steel skid base, rubber isolation mounts, and analog 100 control panel. **All Alternative Fuel Sets are suitable for continuous use.**

125 Alternative Fuel Series

Standby Rating.....	125kW
Amps at 120 Volts.....	1041
Amps at 240 Volts.....	520
Weight (LBS).....	1612



Standard
Analog 100 Panel

Warranty Information
5 Year/5000 hour genset warranty

Delivering excellence one product at a time

Due to product development, all specifications are subject to change without notice

MODEL 125AF

Optional Panels

Options:

- Analog 200 Panel
- Digitec 100 or 300 Panels
- Remote Start
- Manual Transfer Switch
- Automatic Transfer Switch
- 5', 10', 20', or 50' Harness Extensions
- Weather Enclosure
- Sound Abatement
- Electric Blue, Pewter Grey, Midnight Black, or Ultra White Paint

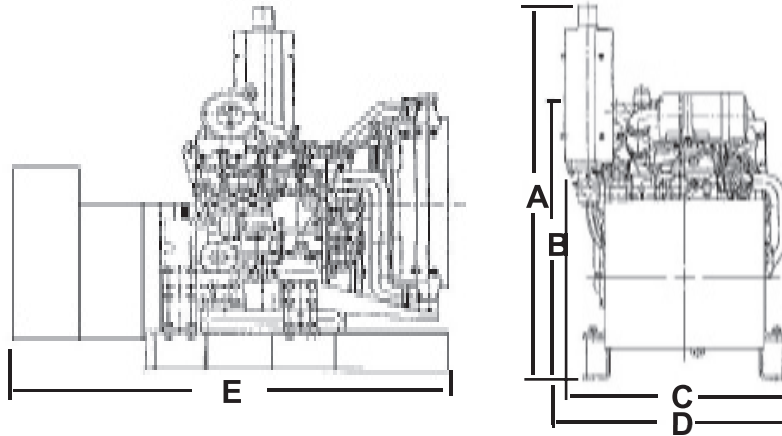

Model	LBS	A	B	C	D	E	AMPS 120	AMPS 240
125AF	1612	56	40	33	41	85	1041	520
Shield	350	60	-	-	41	85	-	-

Authorized Sales and Service Representative

norpro[®] Power Products.

Tel: US (858) 581-3077 Fax: US (858) 274-5523
Email: norpro@williamjwoods.com www.williamjwoods.com/norpro